



PLATE MOUNTED AXIAL FLOW FANS

COMPACT Series type HCFB / HCFT (Plastic impellers)



IP65⁽¹⁾

Range of low profile plate mounted axial fans fitted with **plastic impellers** (250 to 630) or aluminium hub and plastic blades (710 to 1000). Available, depending upon the model, with single or three phase motors in 2, 4, 6 or 8 poles.

Motors

All the motors are **IP65⁽¹⁾**, **Class F** insulation ⁽²⁾, equipped with **thermal protection** ⁽³⁾.

All motors are speed controllable by autotransformer except 2 pole and /4-630, 710, T/800, T/900 and T/1000.

Three phase models are speed controllable by inverter.

Electrical supplies:

Single phase 230V-50Hz. (Capacitor located inside the wiring terminal box).

Three phase 230/400V-50Hz or 400V-50Hz. (See characteristic chart).

⁽¹⁾ 2 pole motor and 800, 900 & 1000 models are IP55.

⁽²⁾ Working temperatures from -40°C up to 70°C. Except models 800 to 1000 suitable for usage in environments from -20 °C to 40°C.

⁽³⁾ Except models 800 to 1000.

Additional Information

Standard air direction: form (A) configuration (Motor over Impeller).

On request

Air direction: form (B) configuration (Impeller over Motor).

Inlet finger proof guard for models 800 to 1000.

A P P L I C A T I O N S

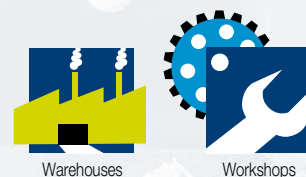

Warehouses

Workshops



Commercial premises

Car parks



Agricultural extract or supply applications

Greenhouses



Painting Installations

Air conditioning equipment

COMPACT HCFB / HCFT

Plate mounted axial flow fans

Compact design



Compact design created by the combination of the motor with the factory matched direct drive wrap around impeller hub

Corrosion resistance



Mounting plate, motor support and finger proof guard protected by cataforesis primer and black polyester paint finish. Stainless steel screws

Terminal box



Wiring terminal box with cable gland PG-11

Impeller dynamically balanced



Impellers are dynamically balanced, according to ISO 1940 standard, giving vibration free operation

Configuration for models Ø 800 to 1000





PLATE MOUNTED AXIAL FLOW FANS

COMPACT Series type HCBB / HCBT (Aluminium impellers)



IP65⁽¹⁾

Range of low profile plate mounted axial fans fitted with **aluminium impellers**.

Available, depending upon the model, with single or three phase motors in 2, 4, 6 or 8 poles.

Motors

All the motors are **IP65⁽¹⁾**, **Class F** insulation ⁽²⁾, equipped with **thermal protection** ⁽³⁾. All motors are speed controllable by autotransformer except and /4-630, B/710, T/4-710, T/800, T/900 and T/1000.

Three phase motors are speed controllable by inverter.

Electrical supplies:

Single phase 230V-50Hz. (Capacitor located inside the wiring terminal box).

Three phase 230/400V-50Hz or 400V-50Hz (See characteristic chart).

- (1) 2/315/H, 2/355/H and 800, 900 & 1000 models are IP55.
- (2) Working temperatures from -40°C up to 70°C (except /2-315/H, /2-355/H, 800, 900 and 1000 models: suitable for usage in environments -20°C to 40 °C).
- (3) Except models 2/315/H, 2/355/H and Ø 800 to 1000.

Additional Information

Standard air direction: form (A) configuration (Motor over Impeller).

On request, explosion proof versions in accordance to ATEX Directive for three phase models:

- **Increased safety** Ⓜ II2G EExII T3 (except 250 models and /6 to 355 diameter models).
- **Flame proof only for models 800 to 1000,** Ⓜ II2G EExdIIB T5 or Ⓜ II2G EExdIIC T4. Ⓜ II3D Ex tD 125°C or 135°C.
- Working temperatures from ATEX versions:**
- **from -20°C to 55°C:** /4, 315 to 710 models /6, 450 to 710 models
- **from -20°C to 40°C:** /4-800 model /6-800 model

On request

Air direction: form (B) configuration (Impeller over Motor).

Inlet finger proof guard for models 800 to 1000.

Compact design

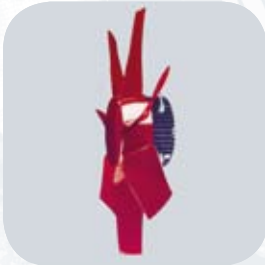

Compact design created by the combination of the motor with the factory matched direct drive wrap around impeller hub

Corrosion resistance



Mounting plate, motor support and finger proof guard protected by cataforesis primer and black polyester paint finish. Stainless steel screws

Terminal box



Wiring terminal box with cable gland PG-11

Impeller dynamically balanced



Impellers are dynamically balanced, according to ISO 1940 standard, giving vibration free operation

Configuration for models Ø 800 to 1000



APPLICATIONS



COMPACT HCBB / HCBT

Plate mounted axial flow fans



Reference

H	C	F	T	/	4	-	4	0	0	/	H	A			
1	2	3	4		5		6		7		8	9			

- 1 - **H**: Compact Plate Axial Fan
- 2 - **C**: Series designation
- 3 - **F**: Impeller Type:
 - F**: Ø 250-Ø 630 Fixed blade plastic impeller
 - Ø 710 - Ø 1000 Aluminium impeller hub and adjustable plastic blade impellers
 - G**: Adjustable plastic blade impellers
 - B**: Ø 250-Ø 400 Fixed blade aluminium impeller
 - Ø 450 - Ø 1000 Adjustable blade aluminium impeller
- 4 - **T**: Electrical supply:
 - B**: Single phase
 - T**: Three phase
- 5 - **A**: Number of poles:
 - 2**: (approx. 2900 r.p.m. - 50 Hz)
 - 4**: (approx. 1400 r.p.m. - 50 Hz)
 - 6**: (approx. 900 r.p.m. - 50 Hz)
 - 8**: (approx. 700 r.p.m. - 50 Hz)
- 6 - **6**: Nominal Diameter of impeller. (mm)
- 7 - **7**: Pitch Angle
 - H: high
 - L: low
- 8 - **8**: Direction of Air:
 - A**: Motor over Impeller
 - B**: Impeller over Motor
- 9 - **9**: Special Construction
 - X**: Motor support without inlet finger guard

- L**: Weatherproof Protected
- C**: Condensation drain holes on motor
- EX**: Explosion proof versions in accordance to ATEX Directive, for three phase models:
 - EXE: Increased safety @II2G EExelIT3
 - EXD: Flame proof, only for models 800 and 1000 @II2G EExdIIBT5 or EExdIICT4
- G**: Special corrosion treatment for agricultural applications
- TF**: With anticorrosive Teflon paint finish

Supply Voltages and Frequencies



Mains supply voltage	Motor type	Connection	Speed
SINGLE PHASE 220V 50Hz, 240V 50Hz	230V 50Hz	See wiring diagram	High
THREE PHASE 220V 50Hz 240V 50Hz	230/400V 50Hz		High
			Low*
THREE PHASE 380V 50Hz 415V 50Hz	230/400V 50Hz		High
			High
	400V 50Hz		Low*

* From sizes 450 up to 630 mm diameter.

Acoustic characteristics

The sound levels shown in the technical characteristic chart, correspond to the value of sound pressure dB(A), measured in free field conditions at a distance equivalent to three times the diameter of the impeller with a minimum of 1.5 meters. Sound power level spectrum in dB(A) at the corresponding frequency band in Hz.

LwA ASP QMAX	63	125	250	500	1000	2000	4000	8000
2-250	50	61	68	73	74	74	67	58
2-315	51	62	82	77	85	85	79	71
2-355	58	63	87	83	89	92	86	79
LwA ASP QMAX	63	125	250	500	1000	2000	4000	8000
4-250	44	50	57	58	60	59	53	42
4-315	37	47	57	61	66	63	57	48
4-355	39	59	56	65	70	66	61	52
4-400	41	62	58	67	74	70	66	43
4-450	40	65	62	68	77	71	67	58
4-500	50	68	67	73	79	77	72	61
4-560	47	72	70	82	82	79	74	65
4-630	52	75	73	81	86	83	77	68
4-710	56	78	76	84	89	86	81	71
4-800/L	61	83	81	89	95	91	86	77
4-800/H	64	86	84	92	98	94	89	80
4-900/L	66	88	86	95	100	96	91	82
4-900/H	70	92	90	97	104	100	95	87
4-1000/L	68	90	88	96	102	98	93	84
4-1000/H	71	93	91	99	105	101	96	87

LwA ASP QMAX	63	125	250	500	1000	2000	4000	8000
6-315	27	37	45	51	52	53	47	36
6-355	39	45	46	52	53	54	48	37
6-400	34	46	49	59	60	60	53	41
6-450	35	50	52	61	64	62	56	45
6-500	39	52	55	63	67	65	59	49
6-560	41	55	60	67	71	70	64	53
6-630	43	59	62	70	71	69	67	56
6-710	51	65	68	77	80	79	73	62
6-800/L	56	70	73	82	85	84	78	67
6-800/H	58	72	75	84	87	86	80	69
6-900/L	61	75	79	87	90	89	83	72
6-900/H	65	79	83	91	94	93	87	76
6-1000/L	63	77	80	89	92	91	85	74
6-1000/H	66	80	83	92	95	94	88	77

LwA ASP QMAX	63	125	250	500	1000	2000	4000	8000
8-450	42	42	47	55	57	58	49	39
8-500	42	42	51	56	59	59	52	42
8-560	46	46	55	60	62	62	55	45
8-630	45	48	57	63	63	64	58	46
8-710	57	57	64	71	73	73	65	55
8-800/L	61	61	69	75	77	77	70	60
8-800/H	63	63	71	77	79	79	72	62
8-900/L	67	67	75	81	83	83	76	76
8-900/H	71	71	79	85	87	87	80	70
8-1000/L	68	68	76	82	84	84	77	67
8-1000/H	72	72	80	86	88	88	81	71

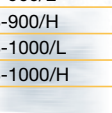

■ Technical characteristics with PLASTIC impellers (HCGB, HCFB, HCGT & HCFT)

Before making any electrical connection ensure that the voltage and frequency of the mains electrical supply matches that of the fan data plate label.

Model	Speed (r.p.m.)	Maximum absorbed power (W)	Maximum current (A)		Sound pressure level (dB(A))	Maximum air volume (m ³ /h)	Weight (kg)	Speed controller		Inverter control		
			at 230 V	at 400 V				REB	RMB/T*	VFTM*	VFKB*	
SINGLE PHASE 2 POLE												
HCFB/2-250/H	2500	250	1,2		65	2200	5	-	-			
HCGB/2-315/L	2500	380	1,7		70	3400	7	-	-			
HCGB/2-355/J	2000	460	2,2		71	4380	8	-	-			
SINGLE PHASE 4 POLE												
HCFB/4-250/H	1330	60	0,3		52	1215	5	REB-1	RMB-1,5			
HCFB/4-315/H	1300	100	0,6		54	2350	7	REB-1	RMB-1,5			
HCFB/4-355/H	1225	200	1,0		58	3490	8	REB-2,5	RMB-1,5			
HCFB/4-400/H	1200	340	1,6		60	5070	9	REB-2,5	RMB-3,5			
HCFB/4-450/H	1290	480	2,3		65	6760	13	REB-2,5	RMB-3,5			
HCFB/4-500/H	1290	650	3,0		68	9200	16	REB-5	RMB-3,5			
HCFB/4-560/H	1250	980	4,9		71	12480	22	REB-5	RMB-8			
HCFB/4-630/H	1200	1700	7,6		72	17060	25	-	-			
SINGLE PHASE 6 POLE												
HCFB/6-315/H	825	80	0,4		45	1560	7	REB-1	RMB-1,5			
HCFB/6-355/H	800	90	0,5		50	2210	8	REB-1	RMB-1,5			
HCFB/6-400/H	750	110	0,6		52	3400	9	REB-1	RMB-1,5			
HCFB/6-450/H	835	220	1,2		53	4550	13	REB-2,5	RMB-1,5			
HCFB/6-500/H	840	290	1,6		56	5820	16	REB-2,5	RMB-3,5			
HCFB/6-560/H	900	420	2,4		59	8260	22	REB-2,5	RMB-3,5			
HCFB/6-630/H	800	510	2,6		60	11000	25	REB-5	RMB-3,5			
HCFB/6-710/H	900	1300	5,7		66	16500	27	-	-			
SINGLE PHASE 8 POLE												
HCFB/8-450/H	625	130	0,7		46	3500	13	REB-1				
HCFB/8-500/H	605	160	0,9		49	4660	16	REB-1				
HCFB/8-560/H	610	240	1,3		52	5990	22	REB-2,5				
HCFB/8-630/H	585	320	1,7		53	8340	25	REB-2,5				
HCFB/8-710/H	625	480	2,4		59	11960	27	-	-			
THREE PHASE 2 POLE												
HCFT/2-250/H	2500	250	0,9	0,5	65	2200	5			-	VFTM-Tri 0,37	VFKB-45
HCGT/2-315/G	2650	410	1,4	0,8	70	3800	7			-	VFTM-Tri 0,37	VFKB-45
HCGT/2-355/I	2380	520	1,6	0,9	71	4400	8			-	VFTM-Tri 0,37	VFKB-45
THREE PHASE 4 POLE												
HCFT/4-250/H	1330	60	0,3	0,2	52	1215	5		RMT-1,5	VFTM-Tri 0,37	VFKB-45	
HCFT/4-315/H	1300	150	0,6	0,3	54	2350	7		RMT-1,5	VFTM-Tri 0,37	VFKB-45	
HCFT/4-355/H	1260	200	0,8	0,5	58	3490	8		RMT-1,5	VFTM-Tri 0,37	VFKB-45	
HCFT/4-400/H	1350	300	1,4	0,8	60	5070	9		RMT-1,5	VFTM-Tri 0,37	VFKB-45	
HCFT/4-450/H	1230	500	1,7	1,0	65	6760	13		RMT-1,5	VFTM-Tri 0,37	VFKB-45	
HCFT/4-500/H	1350	660	2,7	1,6	68	9200	16		RMT-2,5	VFTM-Tri 0,55	VFKB-45	
HCFT/4-560/H	1320	1210	3,9	2,3	71	12480	22		RMT-2,5	VFTM-Tri 0,75	VFKB-45	
HCFT/4-630/H	1420	1550	5,2	3,0	72	17060	25		-	VFTM-Tri 1,1	VFKB-45	
HCFT/4-710/H	1350	2200	7,0	4,0	75	22150	27		-	VFTM-Tri 1,5	VFKB-45	
HCFT/4-800/L-X (1,5 kW)	1420	2300	6,6	3,8	79	24960	37		-	VFTM-Tri 1,5	VFKB-45	
HCFT/4-800/H-X (3 kW)	1430	4200	12,6	7,3	82	31140	52		-	VFTM-Tri 4	VFKB-48	
HCFT/4-900/L-X (3 kW)	1400	4400	11,3	6,5	83	35000	94		-	VFTM-Tri 3	VFKB-48	
HCFT/4-900/H-X (5,5 kW)	1400	7200		12,0	87	45000	110		-	VFTM-Tri 5,5	-	
HCFT/4-1000/L-X (3 kW)	1400	4400	12,3	7,1	84	39240	67		-	VFTM-Tri 3	VFKB-48	
HCFT/4-1000/H-X (5,5 kW)	1460	7200		12,0	87	54000	95		-	VFTM-Tri 5,5	-	

* Three phase speed controllers (RMT) or inverter control (VFKB/VFTM): three phase 400V.

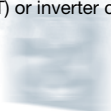



■ Technical characteristics with PLASTIC impellers

Model	Speed (r.p.m.)	Maximum absorbed power (W)	Maximum current (A)		Sound pressure level (dB(A))	Maximum air volume (m ³ /h)	Weight (kg)	Speed controller		Inverter control	
			at 230 V	at 400 V				REB	RMB/T*	VFTM*	VFKB*
THREE PHASE 6 POLE											
HCFT/6-355/H	875	90	0,5	0,3	50	2210	8		RMT-1,5	VFTM-Tri 0,37	VFKB-45
HCFT/6-400/H	830	110	0,5	0,3	52	3400	9		RMT-1,5	VFTM-Tri 0,37	VFKB-45
HCFT/6-450/H	835	190	0,8	0,5	53	4550	13		RMT-1,5	VFTM-Tri 0,37	VFKB-45
HCFT/6-500/H	840	250	0,9	0,5	56	5820	16		RMT-1,5	VFTM-Tri 0,37	VFKB-45
HCFT/6-560/H	900	410	1,6	0,9	59	8260	22		RMT-1,5	VFTM-Tri 0,37	VFKB-45
HCFT/6-630/H	905	530	2,2	1,26	60	11000	25		RMT-1,5	VFTM-Tri 0,37	VFKB-45
HCFT/6-710/H	920	1100	4,9	3,3	66	16500	27		RMT-5	VFTM-Tri 1,5	VFKB-45
HCFT/6-800/L-X (0,55 kW)	900	1180	3,9	2,2	70	16720	31		–	VFTM-Tri 0,75	VFKB 45
HCFT/6-800/H-X (0,75 kW)	940	1220	4,3	2,5	72	20860	36		–	VFTM-Tri 1,1	VFKB 45
HCFT/6-900/L-X (1,1 kW)	950	1400	5,7	3,3	74	23380	86		–	VFTM-Tri 1,5	VFKB 45
HCFT/6-900/H-X (1,5 kW)	950	2330	7,0	4	78	30480	93		–	VFTM-Tri 1,5	VFKB 45
HCFT/6-1000/L-X (1,1 kW)	940	1400	5,6	3,2	75	26290	54		–	VFTM-Tri 1,5	VFKB 45
HCFT/6-1000/H-X (1,5 kW)	950	2330	7,6	4,4	78	36180	62		–	VFTM-Tri 2,2	VFKB 45
THREE PHASE 8 POLE											
HCFT/8-450/H	660	130	0,7	0,4	46	3500	13		RMT-1,5	VFTM-Tri 0,37	VFKB-45
HCFT/8-500/H	625	150	0,7	0,4	49	4660	16		RMT-1,5	VFTM-Tri 0,37	VFKB-45
HCFT/8-560/H	610	230	1,0	0,6	52	5990	22		RMT-1,5	VFTM-Tri 0,37	VFKB-45
HCFT/8-630/H	635	310	1,3	0,8	53	8340	25		RMT-1,5	VFTM-Tri 0,37	VFKB-45
HCFT/8-710/H	670	450	2,0	1,2	59	11960	27		RMT-1,5	VFTM-Tri 0,37	VFKB-45
HCFT/8-800/L-X (0,25 kW)	710	580	2,2	1,3	63	12480	63		–	VFTM-Tri 0,37	VFKB 45
HCFT/8-800/H-X (0,37 kW)	690	700	3,0	1,7	65	17160	64		–	VFTM-Tri 0,55	VFKB 45
HCFT/8-900/L-X (0,37 kW)	700	720	2,8	1,6	69	17450	90		–	VFTM-Tri 0,55	VFKB 45
HCFT/8-900/H-X (0,75 kW)	700	1100	4,5	2,6	72	22750	90		–	VFTM-Tri 1,1	VFKB 45
HCFT/8-1000/L-X (0,37 kW)	700	720	3,0	1,7	68	19620	68		–	VFTM-Tri 0,55	VFKB 45
HCFT/8-1000/H-X (0,75 kW)	725	1100	4,6	2,7	72	27000	71		–	VFTM-Tri 1,1	VFKB 45

* Three phase speed controllers (RMT) or inverter control (VFKB/VFTM): three phase 400V.



■ Technical characteristics with ALUMINIUM impellers (HCBB, HCBT)

Model	Speed (r.p.m.)	Maximum absorbed power (W)	Maximum current (A)		Sound pressure level (dB(A))	Maximum air volume (m ³ /h)	Weight (kg)	Speed controller		Inverter control	
			at 230 V	at 400 V				REB	RMB/T*	VFTM*	VFKB*
SINGLE PHASE 2 POLE											
HCBB/2-250/H	2500	250	1,2		65	2160	5	-	-		
HCBB/2-315/H	2550	730	3,5		75	4800	8	-	-		
HCBB/2-315/L	2500	380	1,7		70	3260	7	-	-		
HCBB/2-355/H	2500	1200	5,0		81	7000	9	-	-		
HCBB/2-355/J	2000	460	2,2		71	4000	8	-	-		
SINGLE PHASE 4 POLE											
HCBB/4-250/H	1330	60	0,3		52	1215	5	REB-1	RMB-1,5		
HCBB/4-315/H	1300	100	0,6		54	2350	7	REB-1	RMB-1,5		
HCBB/4-355/H	1225	200	1,0		58	3490	8	REB-2,5	RMB-1,5		
HCBB/4-400/H	1200	340	1,6		60	5070	9	REB-2,5	RMB-3,5		
HCBB/4-450/H	1290	480	2,3		65	6760	13	REB-2,5	RMB-3,5		
HCBB/4-500/H	1290	650	3,0		68	9200	16	REB-5	RMB-3,5		
HCBB/4-560/H	1250	980	5,9		71	12480	22	REB-10	RMB-8		
HCBB/4-630/H	1200	1700	7,6		72	17060	25	-	-		
SINGLE PHASE 6 POLE											
HCBB/6-355/H	800	90	0,5		50	2210	8	REB-1	RMB-1,5		
HCBB/6-400/H	750	110	0,6		52	3400	9	REB-1	RMB-1,5		
HCBB/6-450/H	835	220	1,2		53	4550	13	REB-2,5	RMB-1,5		
HCBB/6-500/H	840	290	1,6		56	5820	16	REB-2,5	RMB-3,5		
HCBB/6-560/H	900	420	2,4		59	7870	22	REB-2,5	RMB-3,5		
HCBB/6-630/H	800	510	2,6		60	10750	25	REB-5	RMB-3,5		
HCBB/6-710/H	900	1300	5,7		66	17570	27	-	-		
SINGLE PHASE 8 POLE											
HCBB/8-450/H	625	130	0,7		46	3500	13	REB-1	RMB-1,5		
HCBB/8-500/H	605	160	0,9		49	4660	16	REB-1	RMB-1,5		
HCBB/8-560/H	610	240	1,3		52	5990	22	REB-2,5	RMB-1,5		
HCBB/8-630/H	585	320	1,7		53	8340	25	REB-2,5	RMB-3,5		
HCBB/8-710/H	625	480	2,4		59	11960	27	-	-		
THREE PHASE 2 POLE											
HCBT/2-250/H	2500	250	0,9	0,5	65	2160	5			VFTM-Tri 0,37	VFKB-45
HCBT/2-315/H	2750	750	2,1	1,2	75	4800	8			VFTM-Tri 0,37	VFKB-45
HCBT/2-315/G	2650	410	1,4	0,8	70	3800	7			VFTM-Tri 0,37	VFKB-45
HCBT/2-355/H	2700	1200	3,3	1,9	81	7000	9			VFTM-Tri 0,55	VFKB-45
HCBT/2-355/I	2380	520	1,6	0,9	71	4400	8			VFTM-Tri 0,37	VFKB-45
THREE PHASE 4 POLE											
HCBT/4-250/H	1330	60	0,3	0,2	52	1220	5		RMT-1,5	VFTM-Tri 0,37	VFKB-45
HCBT/4-315/H	1300	150	0,6	0,3	54	2350	7		RMT-1,5	VFTM-Tri 0,37	VFKB-45
HCBT/4-355/H	1260	200	0,8	0,5	58	3490	8		RMT-1,5	VFTM-Tri 0,37	VFKB-45
HCBT/4-400/H	1350	300	1,4	0,8	60	5070	9		RMT-1,5	VFTM-Tri 0,37	VFKB-45
HCBT/4-450/H	1230	500	1,7	1,0	65	6760	13		RMT-1,5	VFTM-Tri 0,37	VFKB-45
HCBT/4-500/H	1350	660	2,7	1,6	68	9200	16		RMT-2,5	VFTM-Tri 0,55	VFKB-45
HCBT/4-560/H	1320	1210	3,9	2,3	71	12480	22		RMT-2,5	VFTM-Tri 0,75	VFKB-45
HCBT/4-630/H	1420	1550	5,2	3,0	72	17060	25		-	VFTM-Tri 1,1	VFKB-45
HCBT/4-710/H	1350	2200	7,0	4,0	75	22150	27		-	VFTM-Tri 1,5	VFKB-45
HCBT/4-800/L-X (1,5 kW)	1420	2300	6,6	3,8	79	24960	37		-	VFTM-Tri 1,5	VFKB-45
HCBT/4-800/H-X (3 kW)	1430	4200	12,6	7,3	82	32600	52		-	VFTM-Tri 4	VFKB-48
HCBT/4-900/L-X (3 kW)	1400	4400	11,3	6,5	83	35000	96		-	VFTM-Tri 3	VFKB-48
HCBT/4-900/H-X (5,5 kW)	1400	7200		12,0	87	45000	112		-	VFTM-Tri 5,5	-
HCBT/4-1000/L-X (3 kW)	1400	4400	12,3	7,1	84	42000	67		-	VFTM-Tri 3	VFKB-48
HCBT/4-1000/H-X (5,5 kW)	1460	7200		12,0	87	54000	95		-	VFTM-Tri 5,5	-

* Three phase speed controllers (RMT) or inverter control (VFKB/VFTM): three phase 400V.





■ Technical characteristics with ALUMINIUM impellers

Model	Speed (r.p.m.)	Maximum absorbed power (W)	Maximum current (A)		Sound pressure level (dB(A))	Maximum air volume (m ³ /h)	Weight (kg)	Speed controller		Inverter control	
			a 230 V	a 400 V				REB	RMB/T*	VFTM*	VFKB*
			THREE PHASE 6 POLE								
HCBT/6-355/H	875	90	0,5	0,3	50	2210	8		RMT-1,5	VFTM-Tri 0,37	VFKB-45
HCBT/6-400/H	830	110	0,5	0,3	52	3400	9		RMT-1,5	VFTM-Tri 0,37	VFKB-45
HCBT/6-450/H	835	190	0,8	0,5	53	4550	13		RMT-1,5	VFTM-Tri 0,37	VFKB-45
HCBT/6-500/H	840	250	0,9	0,5	56	5820	16		RMT-1,5	VFTM-Tri 0,37	VFKB-45
HCBT/6-560/H	900	410	1,6	0,9	59	8260	22		RMT-1,5	VFTM-Tri 0,37	VFKB-45
HCBT/6-630/H	905	530	2,20	1,26	60	11000	25		RMT-1,5	VFTM-Tri 0,37	VFKB-45
HCBT/6-710/H	920	1100	4,9	3,3	66	16500	27		RMT-5	VFTM-Tri 1,5	VFKB-45
HCBT/6-800/L-X (0,55 kW)	900	1180	3,9	2,2	70	19370	31		–	VFTM-Tri 0,75	VFKB-45
HCBT/6-800/H-X (0,75 kW)	940	1220	4,3	2,5	72	22000	36		–	VFTM-Tri 1,1	VFKB-45
HCBT/6-900/L-X (1,1 kW)	950	1400	5,7	3,3	74	23500	88		–	VFTM-Tri 1,5	VFKB-45
HCBT/6-900/H-X (1,5 kW)	950	2330	7,0	4	78	30000	95		–	VFTM-Tri 1,5	VFKB-45
HCBT/6-1000/L-X (1,1 kW)	940	1400	5,6	3,2	75	28000	54		–	VFTM-Tri 1,5	VFKB-45
HCBT/6-1000/H-X (1,5 kW)	950	2330	7,6	4,4	78	36400	62		–	VFTM-Tri 2,2	VFKB-45
THREE PHASE 8 POLE											
HCBT/8-450/H	660	130	0,7	0,4	46	3500	13		RMT-1,5	VFTM-Tri 0,37	VFKB-45
HCBT/8-500/H	625	150	0,7	0,4	49	4660	16		RMT-1,5	VFTM-Tri 0,37	VFKB-45
HCBT/8-560/H	610	230	1,0	0,6	52	5990	22		RMT-1,5	VFTM-Tri 0,37	VFKB-45
HCBT/8-630/H	635	310	1,3	0,8	53	8340	25		RMT-1,5	VFTM-Tri 0,37	VFKB-45
HCBT/8-710/H	670	450	2,0	1,2	59	11960	27		RMT-1,5	VFTM-Tri 0,37	VFKB-45
HCBT/8-800/L-X (0,25 kW)	710	580	2,2	1,3	63	14000	63		–	VFTM-Tri 0,37	VFKB-45
HCBT/8-800/H-X (0,37 kW)	690	700	3,0	1,7	65	17160	64		–	VFTM-Tri 0,55	VFKB-45
HCBT/8-900/L-X (0,37 kW)	750	720	2,8	1,6	69	17500	85		–	VFTM-Tri 0,55	VFKB-45
HCBT/8-900/H-X (0,75 kW)	750	1100	4,5	2,6	72	22500	92		–	VFTM-Tri 1,1	VFKB-45
HCBT/8-1000/L-X (0,37 kW)	700	720	3,0	1,7	68	20490	68		–	VFTM-Tri 0,55	VFKB-45
HCBT/8-1000/H-X (0,75 kW)	725	1100	4,6	2,7	72	27040	71		–	VFTM-Tri 1,1	VFKB-45

* Three phase speed controllers (RMT) or inverter control (VFKB/VFTM): three phase 400V.

COMPACT

Plate mounted axial flow fans

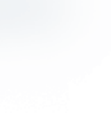

■ Dimensions (mm)

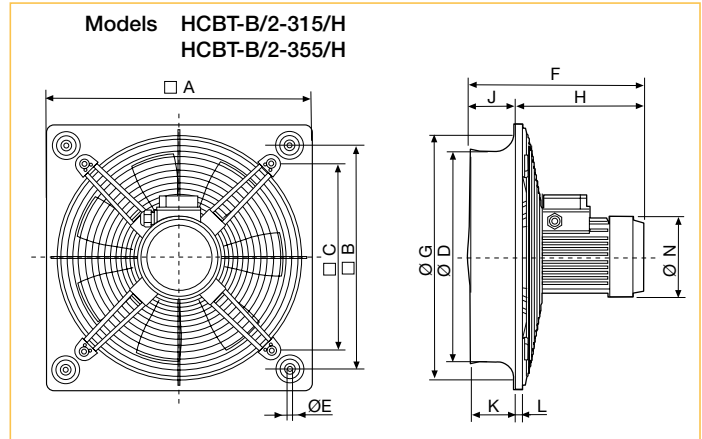
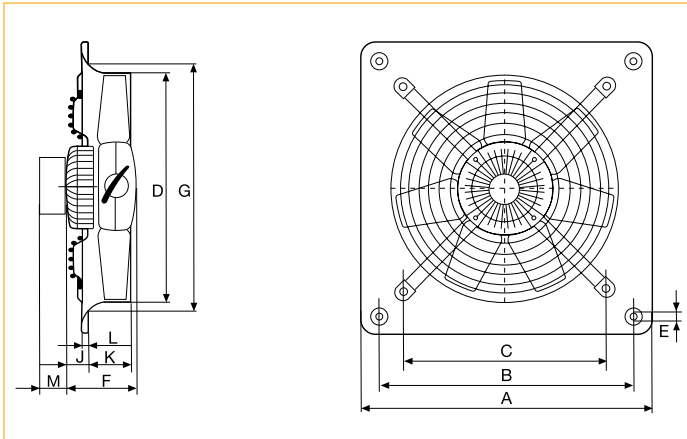

Model	A	B	C	Ø D	Ø E	F				Ø G	J				K	L	M	
						Number of Poles					Number of Poles						Three phase	Single phase
						/2	/4	/6	/8		/2	/4	/6	/8				
250	315	260	220	254	10	122	122			294	59	59			53	12	40	65
315	400	330	280	315	10	129	122	122		329	45	32	32		68	12	40	65
355	450	380	315	355	10	129	129	129		371	45	45	45		75	12	40	65
400	500	420	355	400	10		129	129		422		40,5	40,5		78	12	40	65
450	560	480	400	450	10		150	150	150	476		48	48	48	91	12	40	65
500	630	560	450	500	10		150	150	150	536		44,5	44,5	44,5	97	12	40	65
560	710	630	510	560	10		218,5	150	150	596		110,5	42	42	98,5	12	40	65
630	800	710	580	630	12		218,5	150	150	674		110,5	41	41	103	12	40	65
710	900	800	636	710	12		218,5	218,5	218,5	733		134	134	134	91,5	16,5	40	65

Model	A	B	C	Ø D	Ø E	F	Ø G	H	J	K	L	Ø N
HCBT-B/2-315/H	400	330	280	315	10	298	329	220,5	77,5	68	12	135
HCBT-B/2-355/H	450	380	315	355	10	298	371	219	79	75	12	135

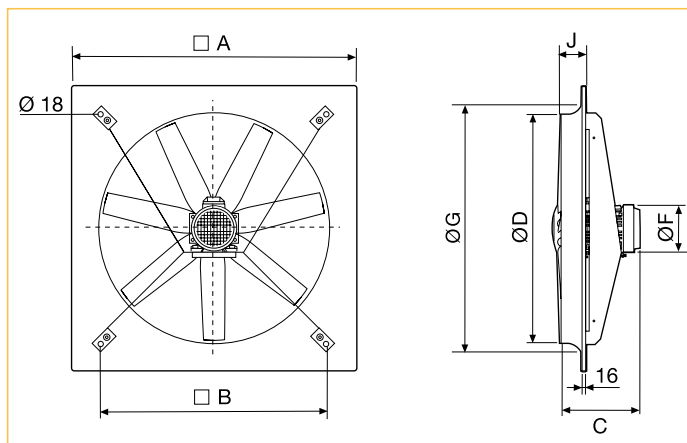

Model	A	B	Ø D	J	Ø G	C						Ø F					
						/4		/6		/8		/4		/6		/8	
						L	H	L	H	L	H	L	H	L	H	L	H
800	1000	800	800	92	926	345	380	310	345	310	345	181	203	162	181	162	181
900	1120	900	900	120	1060		439						306				
1000	1250	1000	1000	110	1154	380	485	345	380	345	380	203	280	181	203	181	203



Installation accessories

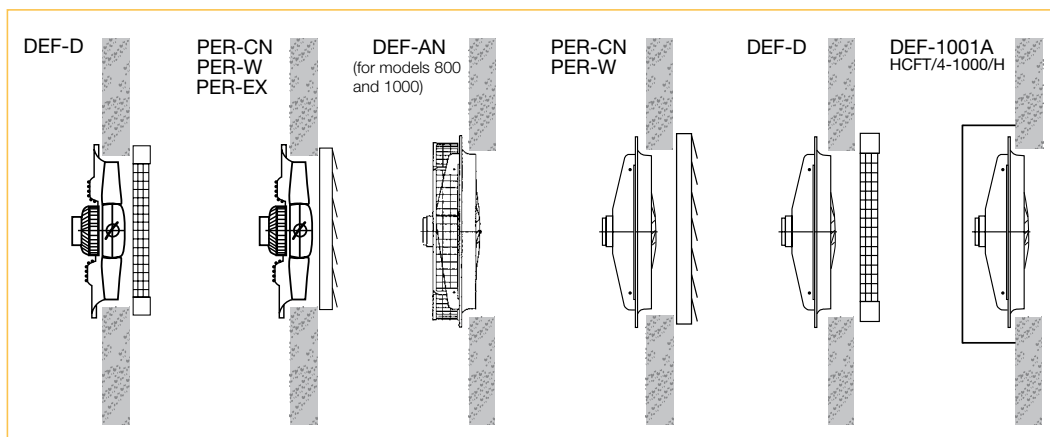

Model	HCFB/HCFT HCBB/HCBT	Wire Protection Guards		Exhaust Side Louvre Shutters		
		Outlet	Inlet	Plastic	Aluminium	ATEX version*
250		DEF-250 D	-	PER-250 W	PER-250 CN	PER-315 Ex
315		DEF-325 D	-	PER-355 W	PER-355 CN	PER-315 Ex
355		DEF-375 D	-	PER-355 W	PER-355 CN	PER-355 Ex
400		DEF-450 D	-	PER-400 W	PER-400 CN	PER-400 Ex
450		DEF-450 D	-	PER-450 W	PER-450 CN	PER-450 Ex
500		DEF-525 D	-	PER-500 W	PER-500 CN	PER-500 Ex
560		DEF-630 D	-	PER-560 W	PER-630 CN	PER-560 Ex
630		DEF-630 D	-	PER-630 W	PER-630 CN	PER-630 Ex
710		DEF-800 D	-	PER-710 W	PER-710 CN	PER-710 Ex
800		DEF-800 D	DEF-800 AN	PER-800 W	PER-800 CN	-
900/4		DEF-1000 D	DEF-900 AN	PER-1000 W	PER-1000 CN	-
900/6		DEF-1000 D	DEF-901 AN	PER-1000 W	PER-1000 CN	-
1000		DEF-1000 D	DEF-1000 AN	PER-1000 W	PER-1000 CN	-
HCFT / 4-1000 / H		DEF-1000 D	DEF-1001 AN	PER-1000 W	PER-1000 CN	-

* Only can be mounted with HCBT explosion proof versions. For more information see mounting accessories.

Electrical accessories



REB-1N / REB-2,5N
Single phase electronic speed controllers



REB-5 / REB-10
Single phase electronic speed controllers



RMB/RMT
Single and three phase auto transformer speed controllers



REB-4 Auto
Electronic single phase speed controllers with temperature sensor. For agricultural applications



VFKB
Adjustable frequency drives for three phase motors from 0,37 to 4 kW. 230 V or 400 V



COM D/S
To connect three phase fans with 400 V motor. For three phase models



VFTM IP54
Adjustable frequency drive for three phase motors from 0,37 to 15 kW. 230 V or 400 V



■ Performance curves – HCFB/HCFT – HCBB/HCBT – TCFB/TCFT Series

- Q = Air volume in, m³/hr and m³/s.
- Ps = Static pressure in mmWG and Pa.
- Dry air at 20°C and 760 mmHg.
- Performance data in accordance with ISO 5801 and AMCA 210-99 Standards.

Typical fan selection:

Do not select the working point in the coloured area. To find the working point it is first necessary to plot the system resistance curve. The working point lies at the intersection between that curve and the fan performance curve.

Example: Required air volume 10.000 m³/h at 3 mmWG.
Fan working point 11.300 m³/h at 4 mmWG.

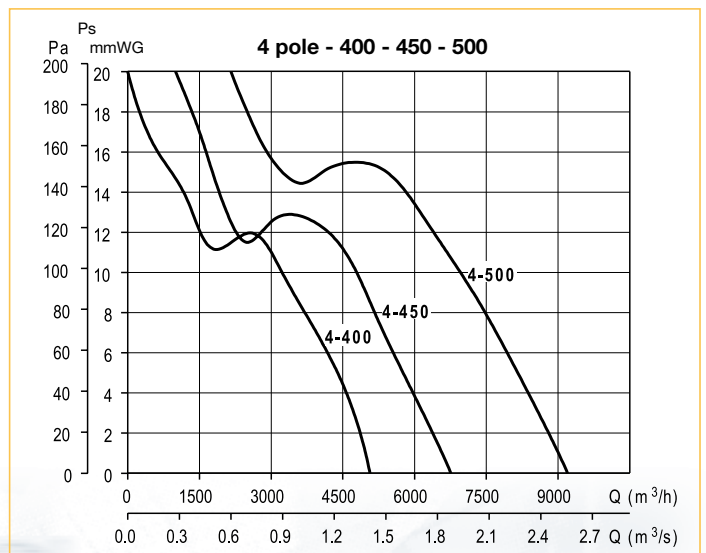
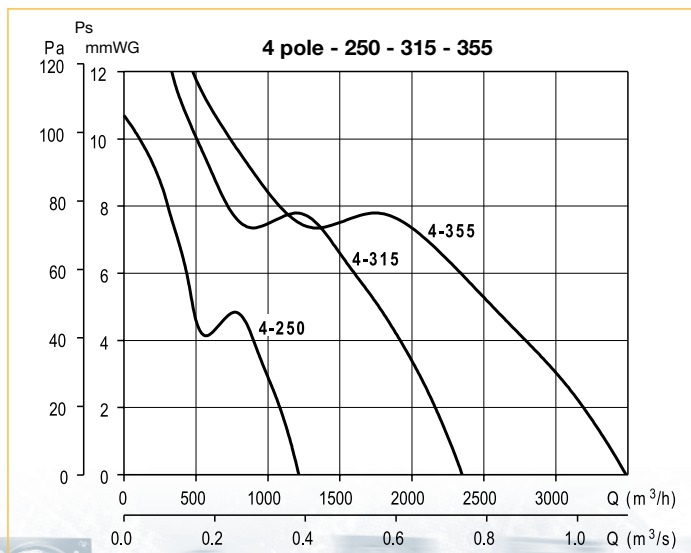
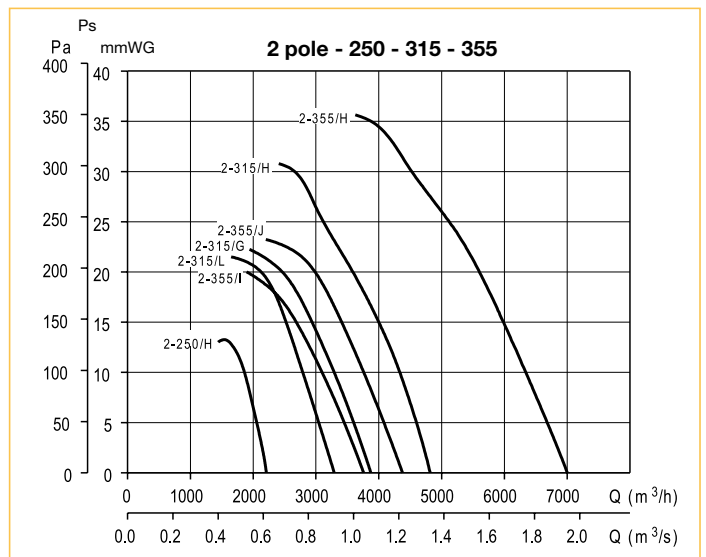
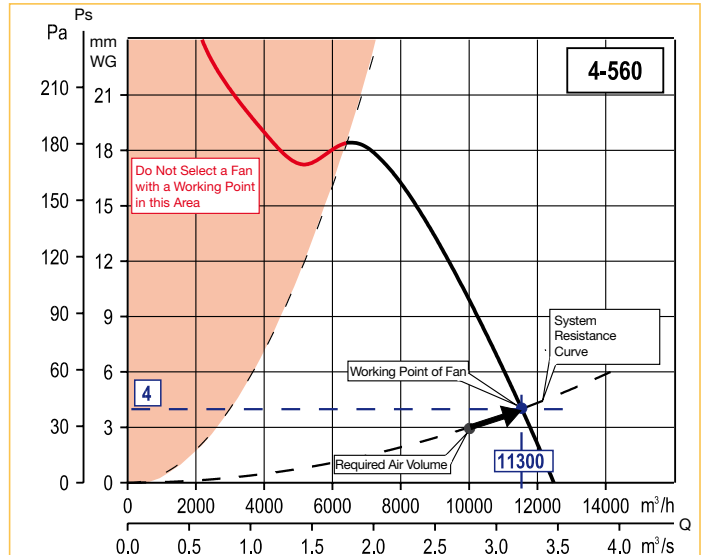

Performance curves - HCFB/HCFT - HCBB/HCBT - TCFB/TCFT Series

- Q = Air volume in, m³/hr and m³/s.
- Ps = Static pressure in mmWG and Pa.
- Dry air at 20°C and 760 mmHg.
- Performance data in accordance with ISO 5801 and AMCA 210-99 Standards.

COMPACT

Plate mounted axial flow fans

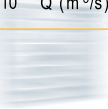
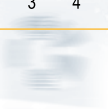
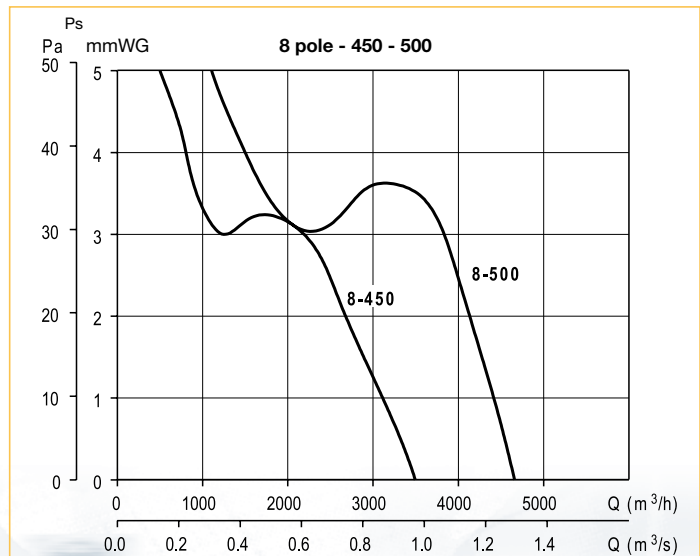
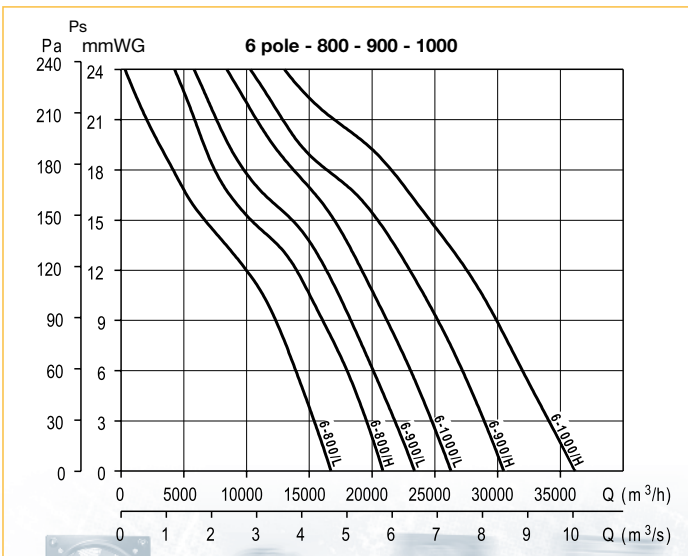
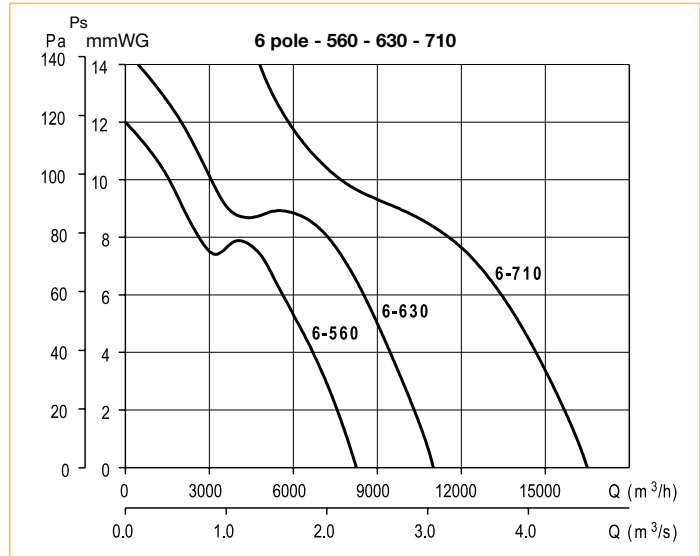
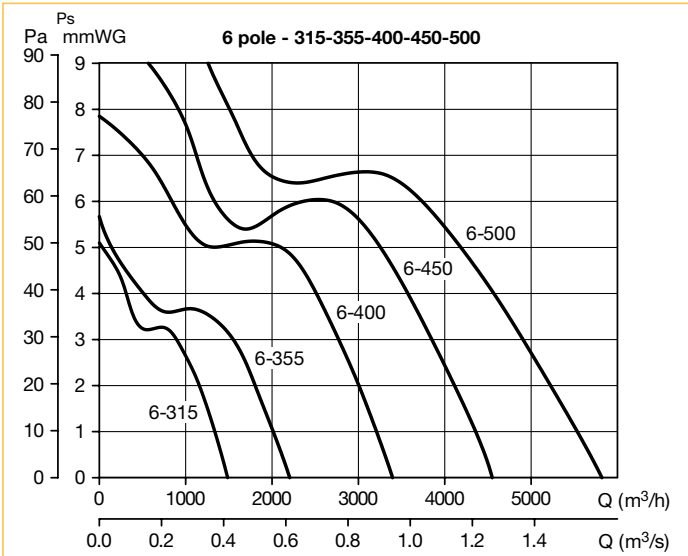
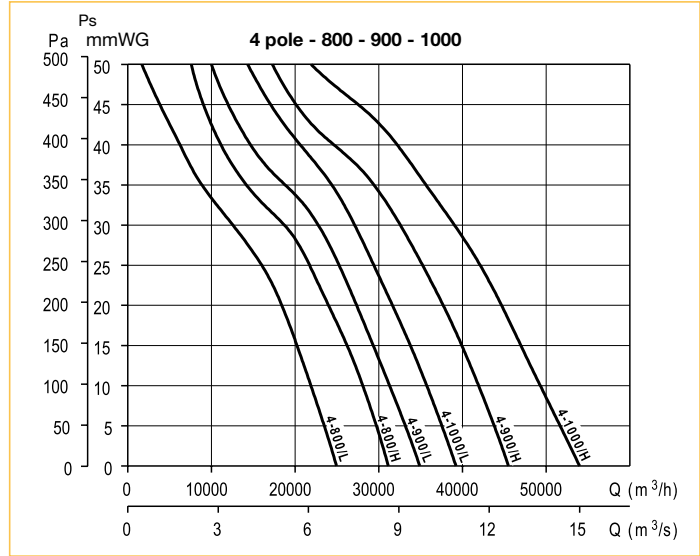
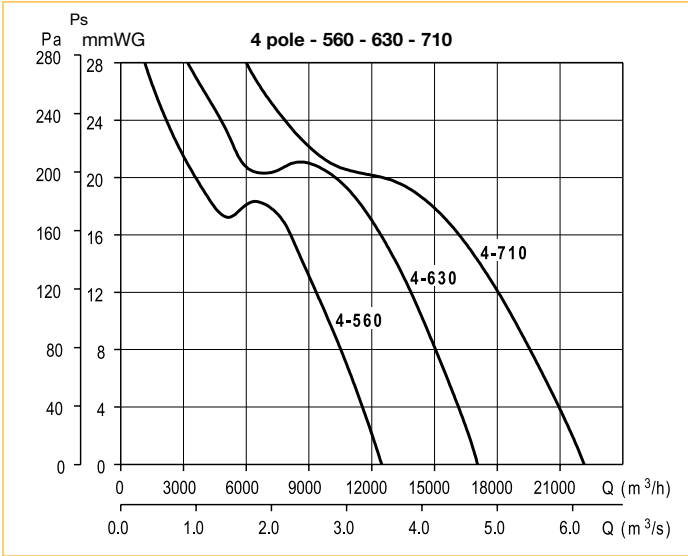

■ Performance curves – HCFB/HCFT – HCBB/HCBT – TCFB/TCFT Series

- Q = Air volume in, m³/hr and m³/s.
- Ps= Static pressure in mmWG and Pa.
- Dry air at 20°C and 760 mmHg.
- Performance data in accordance with ISO 5801 and AMCA 210-99 Standards.

